

CAST IRON DUAL PLATE CHECK VALVE NBR

Cast iron dual plate check valve for heating and water distribution.

Cast iron EN GJL-250 body coated with anti-corrosion epoxy painting, nickered ductile iron disc and vulcanized NBR seat.

Wafer type with short length and with a hoisting eye from DN200 to 600 for easy installation.



Size : DN40 to DN600

Connection : Between flanges PN10/16, Class 150 (PN20)

Min Temperature : -10°C

Max Temperature : +80°C

Max Pressure : 16 Bars up to DN300

Specifications : NBR vulcanized seat

Horizontal or vertical position with ascendant fluid

Wafer type

Hoisting eye from DN200 to 600

Weak headloss

Materials : Cast iron EN GJL-250 body

CAST IRON DUAL PLATE CHECK VALVE NBR

SPECIFICATIONS :

- Vulcanized gasket
- Hoisting eye from DN200 to 600
- Short length
- Anti-corrosion stainless steel spring
- PTFE bushing
- Weak head loss
- Vertical position with ascendant fluid or horizontal position (respect the flow direction indicated by the arrow)
- Between flanges PN10/16, and Class 150 PN20
- From DN50 to DN80 : 4 holes on the body to be compatible Class 150 (PN20)
- Epoxy painting RAL5005 80 microns thickness
- Minimum backpressure for tightness : 2 bars

USE :

- Heating, water distribution
- Min and max Temperature Ts : - 10°C to + 80°C (100°C temporarily)
- Max Pressure Ps : 16 bars up to DN300 included and 10 bars over
- **Do not use with pulsatory speed**

HEAD LOSS GRAPH :

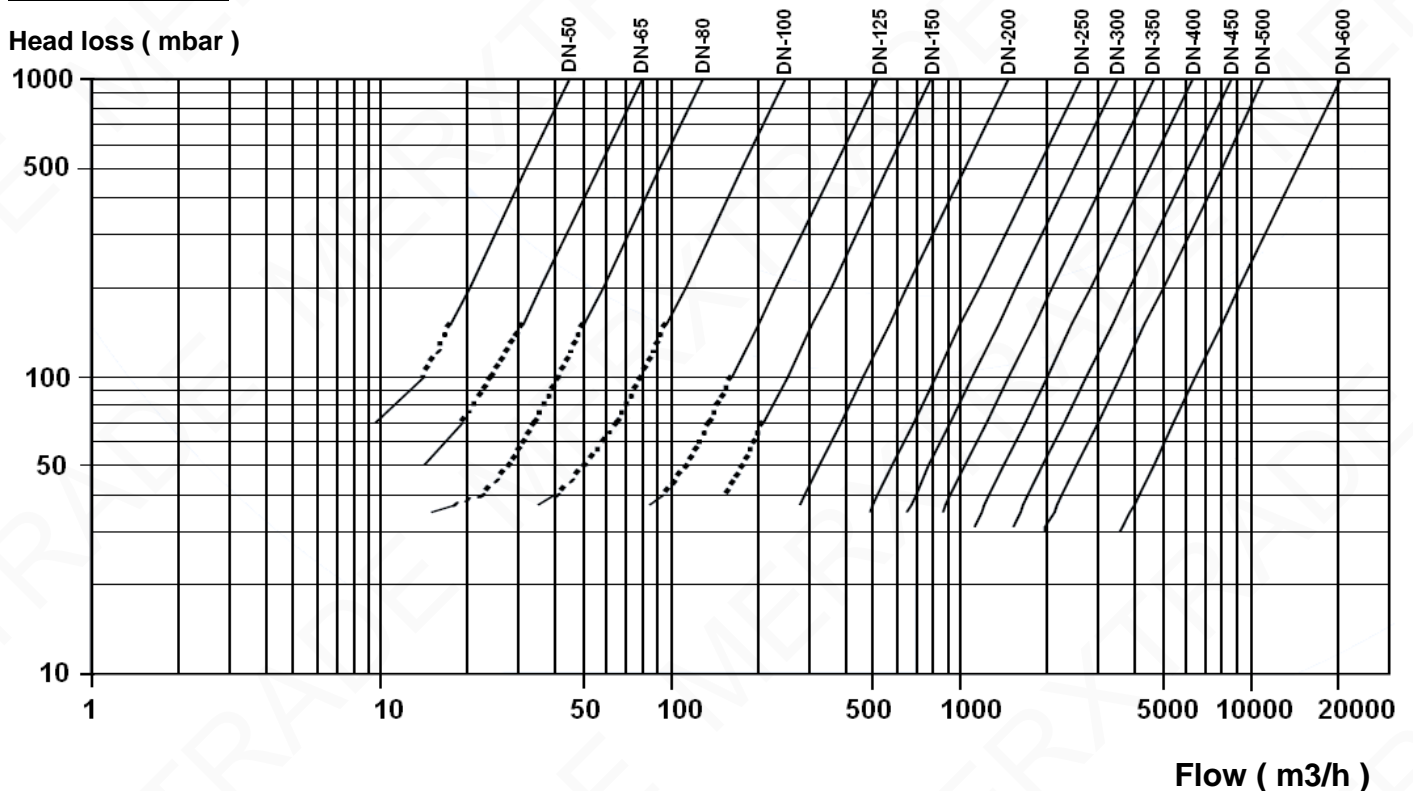

OPENING PRESSURE (in mbar) :

DN	40	50	65	80	100	125	150	200	250	300
Horizontal position	150	230	94	190	280	160	79	41	38	31
Vertical position ascend. fluid	190	260	114	230	320	180	95	57	58	56

CAST IRON DUAL PLATE CHECK VALVE NBR

RANGE :

- Dual plate check valve with cast iron body and ductile iron disc between flanges PN10/16 Ref. 370 From DN40 to DN 600
- Between flanges Class 150 PN20 possible
- From DN50 to DN80, 4 holes on the body to be compatible Class 150 (PN20)

For the connection PN10/16 in DN50 with holes, use the 2 rings for a good centering

MATERIALS DN40-80 :

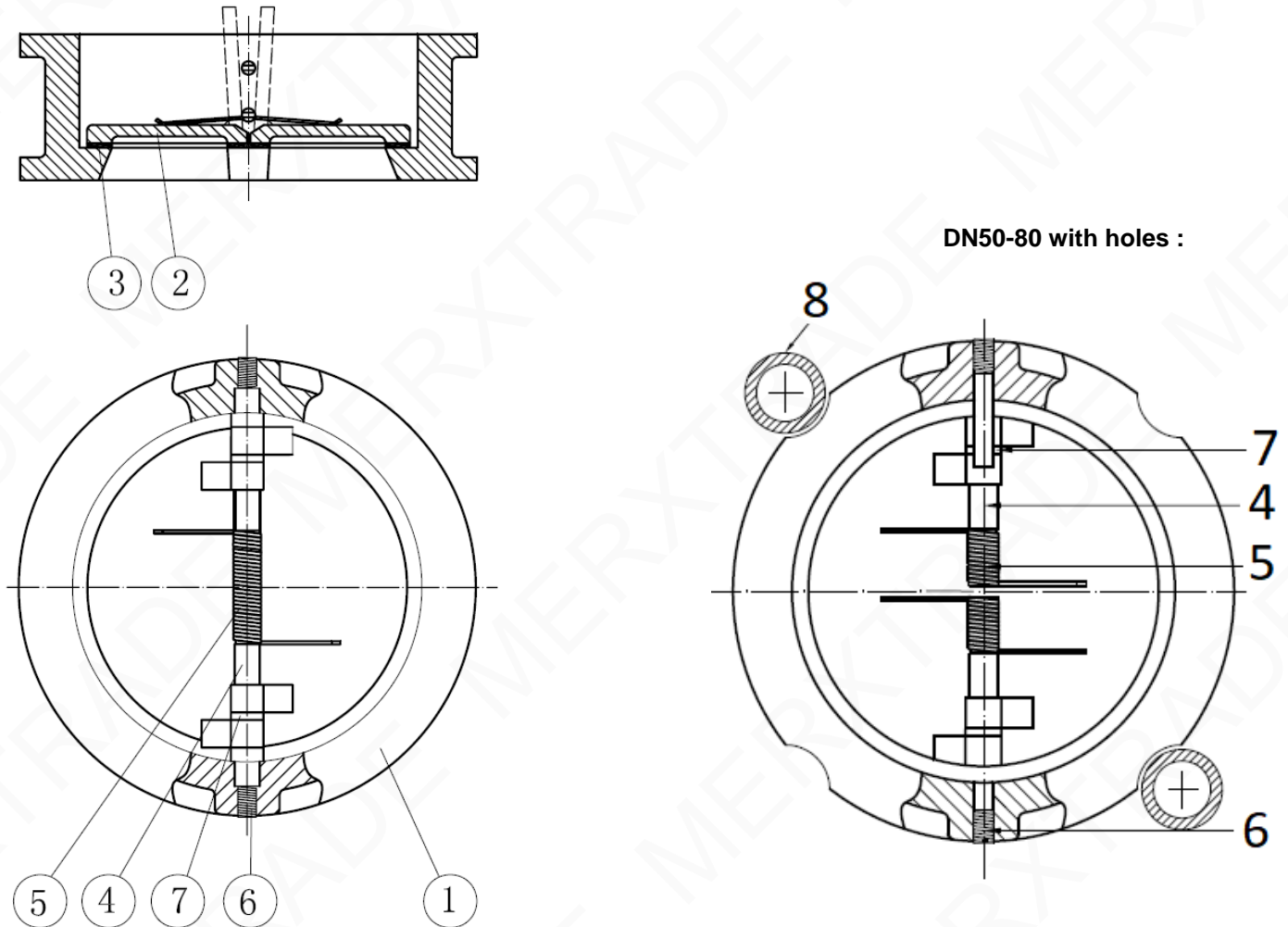

Item	Designation	Materials
1	Body	Cast iron EN-GJL 250
2	Disc	Nickeled ductile iron EN-GJS 400-15
3	Seat	NBR
4	Shaft	AISI 304
5	Spring	
6	Screw	Galvanized carbon steel
7	Spacer	PTFE
8 (only for DN50)	Ring	PPR

CAST IRON DUAL PLATE CHECK VALVE NBR

MATERIALS DN100 - 600 :

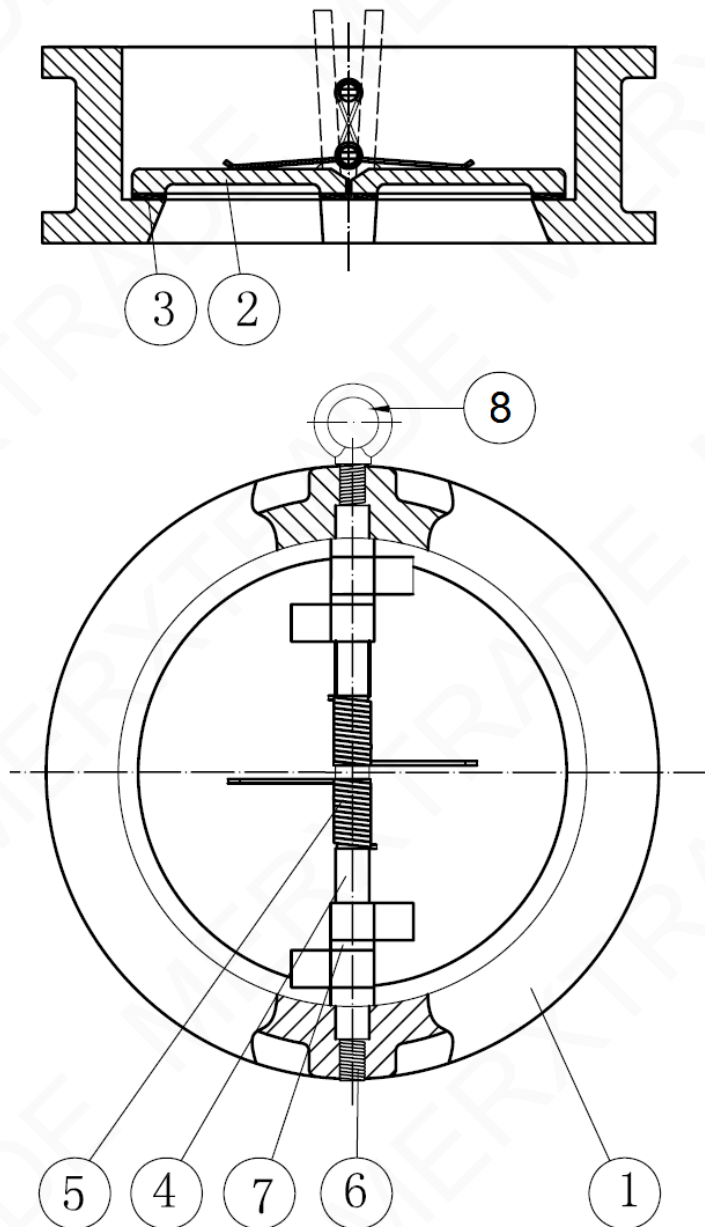

Item	Designation	Materials
1	Body	Cast iron EN-GJL 250
2	Disc	Nickel ductile iron EN-GJS 400-15
3	Seat	NBR
4	Shaft	AISI 304
5	Spring	
6	Screw	Galvanized carbon steel
7	Spacer	PTFE
8	Hoisting eye (from DN200 to 600)	AISI 304

CAST IRON DUAL PLATE CHECK VALVE NBR

SIZE (in mm) :

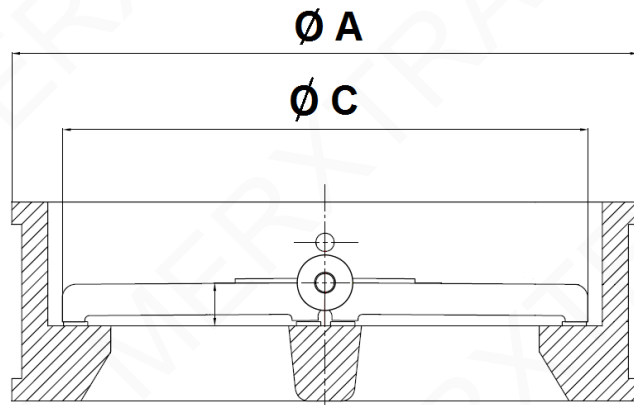
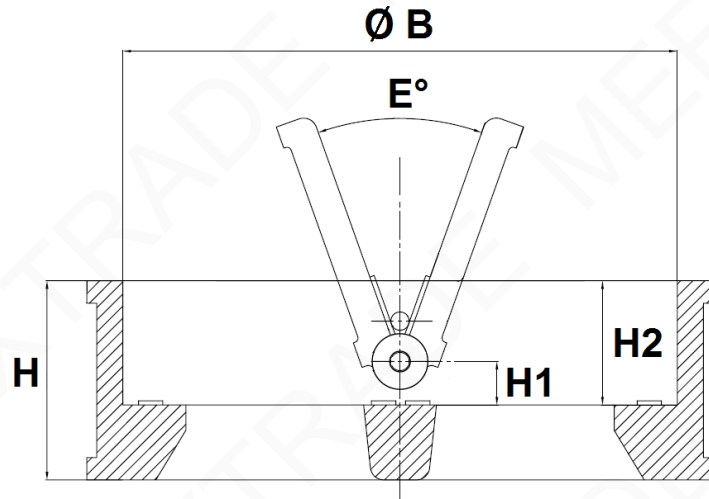

DN	40	50	65	80	100	125	150	200	250	300	350	400	450	500	600
H	43	54	54	57	64	70	76	95	108	143	184	191	203	213	222
H1	12	14.4	16.9	19.9	21	22.3	22.5	28	34	37	35	37.5	42.2	39.5	48.5
H2	33	43	43	45	47	51	54	69	71	100	120	123	122.6	132	138.5
Ø A	82	109	129	144	164	194	220	275	330	380	440	491	541	596	697
Ø B	56.5	70.5	83.5	91.5	115.5	142.5	169.5	220.5	275.5	325.5	356	406	467	514	616
Ø C	52	60.5	75.8	80.5	104.5	130.3	155.9	201.2	257.2	303.3	345.9	388.6	431.2	486.8	607.6
E°	0°	0°	0°	0°	0°	0°	0°	0°	0°	0°	20°	20°	20°	25°	25°
Weight (Kg)	1.6	1.62	2.3	3.14	4.5	6.7	9.05	16	26.9	38.9	80	106	128	158	225

CAST IRON DUAL PLATE CHECK VALVE NBR

STANDARDS :

- Manufacturer certified ISO 9001 : 2015
- DIRECTIVE 2014/68/EU : For liquids and gas of Group 1
 - DN40-50 : Risk category I, CE marking
 - DN65-200 : Risk Category II, CE 0035 marking
 - DN250-300 : Risk Category III, CE 0035 marking
 - DN350 : Risk Category II, CE 0035 marking
 - DN400-600 : Risk Category III, CE 0035 marking
- Certificate 3.1 on request
- Designing according to API 594
- Pressure tests according to API 598, table 6
- Length according to EN 558 Series 50
- Between flanges according to EN 1092-1 PN10/16
- Check valves according to LR Rules and Regulation for the classification of Ships, July 2019 (Type Approval Certificate) **Marine LLOYD'S REGISTER**. LR Type Approval System Test Specification Number 2, Chapter 8, Appendix 7-Valves :
 - BS EN 12266-1 : 2003
 - ISO 52008:2008
 - BS EN 1561
 - BS EN 1563
 - ASTM A431

INSTALLATION POSITIONS :

Vertical position (ascendant fluid)

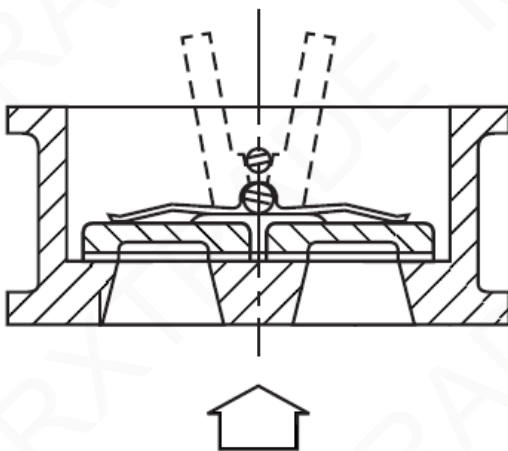

Horizontal position

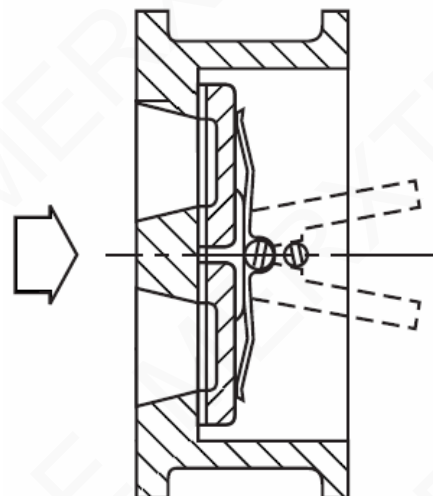

ADVICE : Our opinion and our advice are not guaranteed and Merxtrade shall not be liable for the consequences of damages. The customer must check the right choice of the products with the real service conditions.